

# E36 M3 5<sup>th</sup> And Reverse Gear Selector Shaft Pin Bushing Replacement Instructions (Transmission Removed)

Attachment SI B23 04 04 dated 1/2005

## Special tools required:

- 00 1 450
- 23 0 170
- 23 4 021
- 23 4 022
- 23 4 023

Place transmission (1) with special tool 23 0 170 on assembly stand 00 1 450.

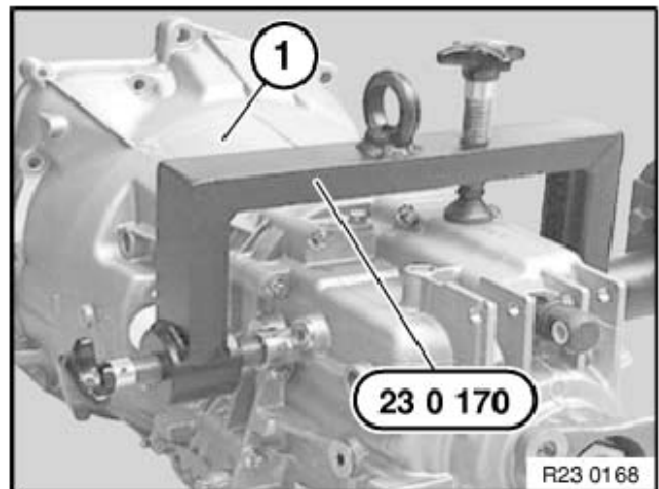

## Note:

1=Locking pin for reverse gear

2=Locking pin for 5th gear

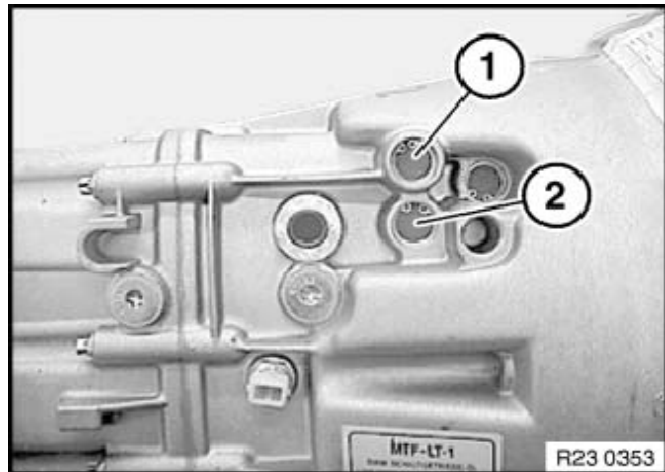

Release retaining ring (1).

Drive sealing cap (2) out of transmission housing with a suitable tool.

**Important!**

Bore must not be damaged. A burr or a dent can cause the sealing cap to leak.

**Installation:**

Replace sealing cap (2).

**Note:**

Illustration shows sealing cap for reverse gear

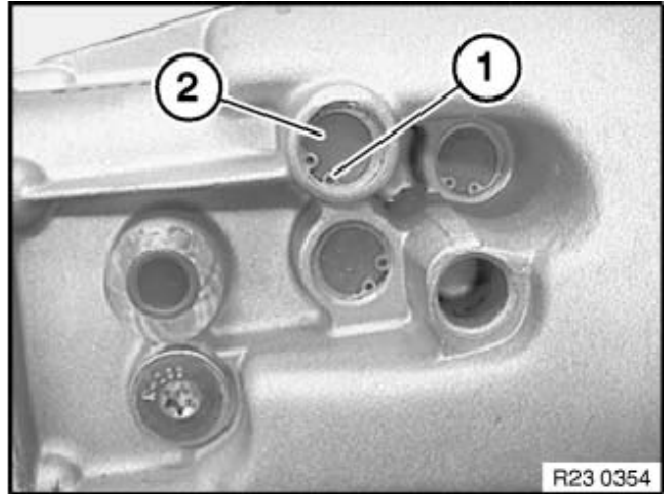

Remove pressure spring and locking pin.

**Important!**

Pressure spring and locking pin for reverse and 5th gears must not be mixed up.

5th gear locking pin	Reverse gear locking pin
Curved slant	Straight slant
Weaker pressure spring	Stronger pressure spring

**Installation:**

Reverse gear locking pin:

Slant must point downwards in bell housing in direction of travel!

5th gear locking pin:

Slant must point upwards in bell housing in direction of travel!

**Note:**

Illustration shows: 5th gear pressure spring!

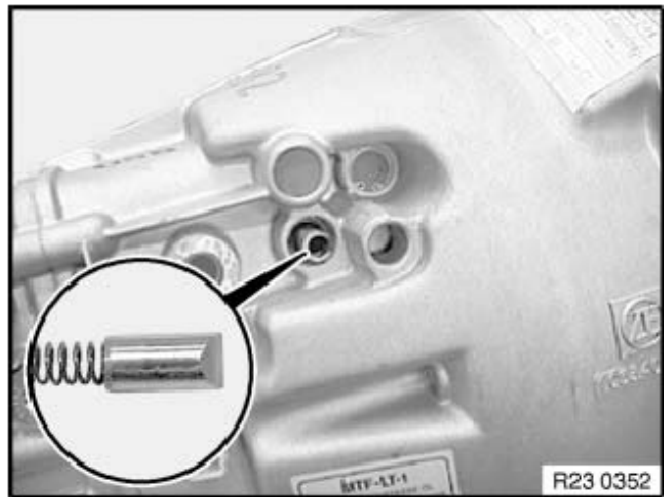

Force open bearing bushing (1) and withdraw using a suitable tool.

**Important!**

Force open bearing bushing (1) at specified indent (2) only.

Bore surface must not be damaged!

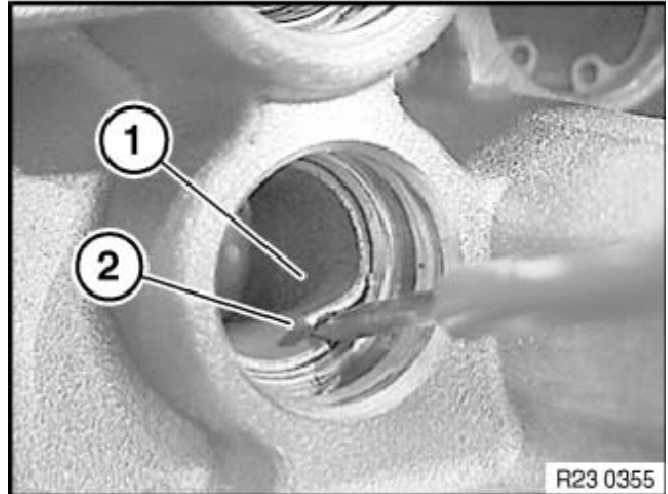

Drive in bearing bushing (1) with special tool (see table).

**Important!**

Make sure you use the correct special tool.  
Different tools have different dimensions!

5th gear	23 4 022 (short)
Reverse gear	23 4 023 (long)

Drive in sealing cap (1) with special tool 23 4 021.

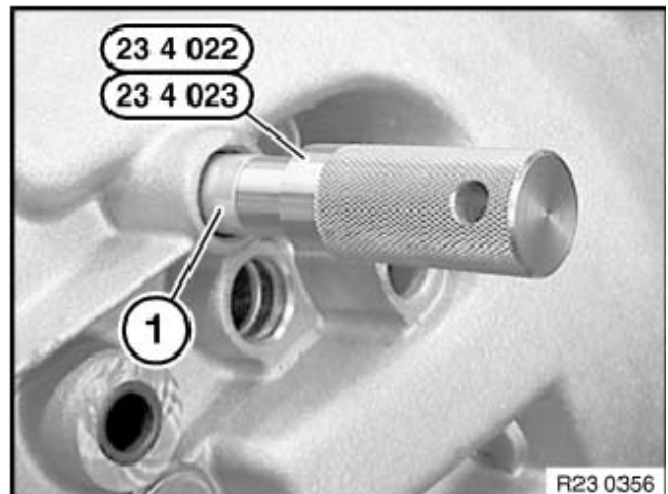

Fit retaining ring using special tool 23 4 021.

